

Check Valve, Ball-type

VJO1-10/S

Size 10 / M20x1.5 • Q_{max} 80 l/min (21 GPM) • p_{max} 350 bar (5100 PSI)

Technical Features

- › Hardened precision parts
- › Sharp-edged steel seats for dirt-tolerant performance
- › Leak-free closing, suitable for fast cycling with long life
- › Compact design for limited installation space availability
- › High flow capacity
- › In the standard version, the valve is without surface coating

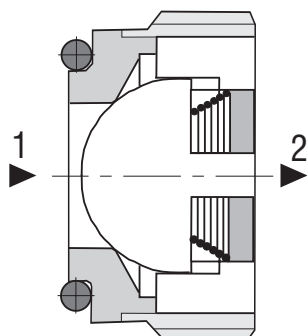

Functional Description

A hydraulic check valve in the form of a screw-in cartridge-style for use as a blocking or load-holding device. The cartridge has a ball check which is closed by spring until sufficient pressure is applied at port 1 to open flow to port 2.

Symbol	
--------	--

Technical Data

Valve size		10 / M20x1.5
Max. flow	l/min (GPM)	80 (21.1)
Max. operating pressure	bar (PSI)	350 (5076)
Cracking pressure	bar (PSI)	0.5 (7.25)
Fluid temperature range (NBR)	°C (°F)	-30 +100 (-22 ... +212)
Fluid temperature range (FPM)	°C (°F)	-20 +120 (-4 ... +248)
Mass	kg (lbs)	0.017 (0.038)

	Datasheet	Type
General information	GI_0060	Products and operating conditions
Spare parts	SP_8010	

Characteristics measured at $v = 32 \text{ mm}^2/\text{s}$ (156 SUS)

Pressure drop related to flow rate

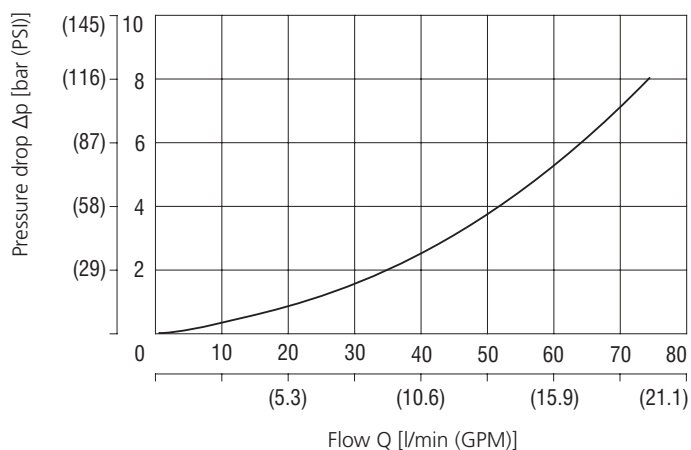

Dimensions in millimeters (inches)

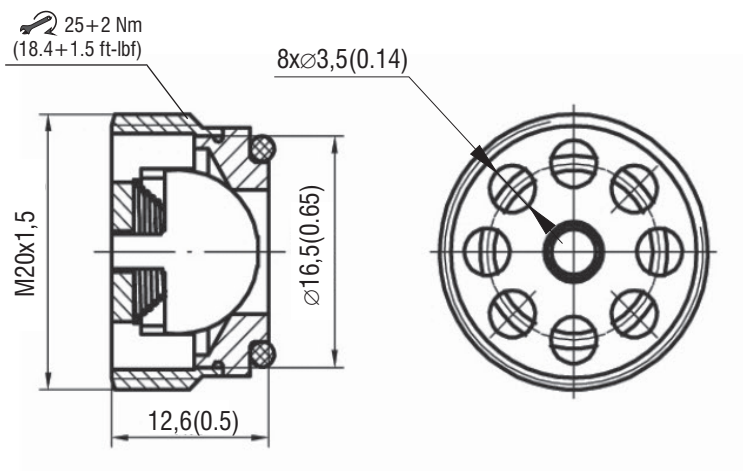

Cavity in millimeters (inches)

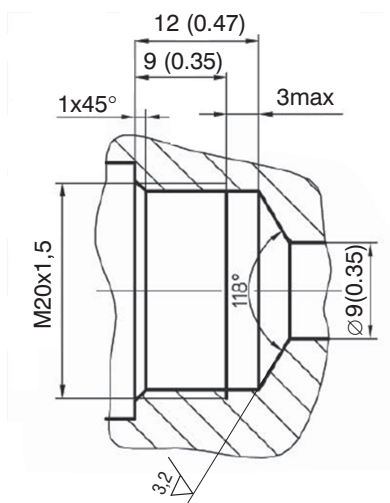

Ordering Code

	VJO1-10 / S	<input type="checkbox"/>	<input type="checkbox"/>	<input type="checkbox"/>	
Check Valve, ball-type					
Valve size				No designation V	Seals NBR FPM (Viton)
Screw-in					
Thread M20x1.5		M		005	Cracking pressure 0.5 bar (7.30 PSI)