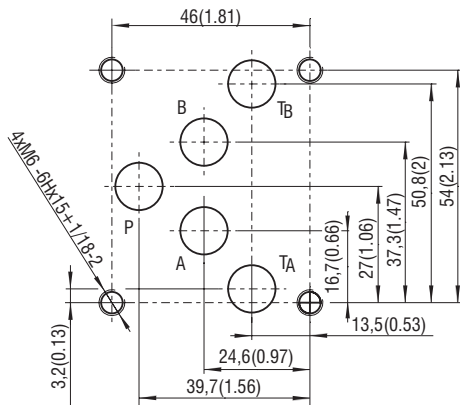

Technical Features

- › 3-Way pressure compensator, spool-type, direct-acting with subplate interface acc. to ISO 4401, DIN 24340 (CETOP 05)
- › Modular design for vertical stacking assemblies with built-in load sensing shuttle valve
- › Meter-in flow control models with load sensing from optional consumer ports
- › The valve keeps the pressure drop between the inlet and the pilot connection at a constant level
- › Used as a load sensing valve with proportional directional and flow valves to control the flow rate independently of pressure variations
- › Excellent stability throughout flow range with rapid response to dynamic pressure changes
- › Adjustable by allen key or hand knob, or delivered with fix setting
- › Quiet and modulate response to load changes
- › Hardened precision parts
- › High flow capacity
- › In the standard version, the valve housing is phosphated and steel parts are zinc-coated for 240 h protection acc. to ISO 9227

ISO 4401-05-04-0-05

 Ports P, A, B, T - max. \varnothing 11.2 mm (0.44 in)

Functional Description

A normally closed, direct-acting, spring loaded 3-way pressure compensator valve in the form of a sandwich plate. It consists of a body, a 3-way screw-in cartridge compensator TV2-103/S and a load shuttle valve. Ports A and B are always connected through the load shuttle valve with the spring chamber of the pressure compensator cartridge valve.

Typically, 3-way pressure compensators are used as meter-in regulators in parallel with flow restrictor valves when raising or lowering variable loads at the same velocity is required. The pressure compensator valve then keeps the pressure difference between its pressure inlet and the pressure at the output port of the regulated flow valve nearly constant. When the pressure differential exceeds the pre-set value, the pressure compensator opens and releases excessive flow from the main circuit to port B. If there is no flow demand from the consumer, the compensator allows the oil to flow back to tank and therefore vents the whole system. This prevents the hydraulic system from overheating especially in load sensing circuits with a fixed displacement pump.

Technical Data

Valve size		10 (D05)
Max. operating pressure	bar (PSI)	350 (5100)
Max. flow	l/min (GPM)	80 (21.1)
Control pressure differential	bar (PSI)	4 ... 14 (58 ... 203)
Fluid temperature range (NBR)	°C (°F)	-30 ... +100 (-22 ... +212)
Fluid temperature range (FPM)	°C (°F)	-20 ... +120 (-4 ... +248)
Mass (all models)	kg (lbs)	1.0 (2.2)

	Data Sheet	Type
General information	GI_0060	Products and operating conditions
Mounting interface	SMT_0019	Size 10
Spare parts	SP_8010	

Characteristics measured at $v = 32 \text{ mm}^2/\text{s}$ (156 SUS)

Regulated flow related to input pressure

TV2-103/MC Meter-in compensator

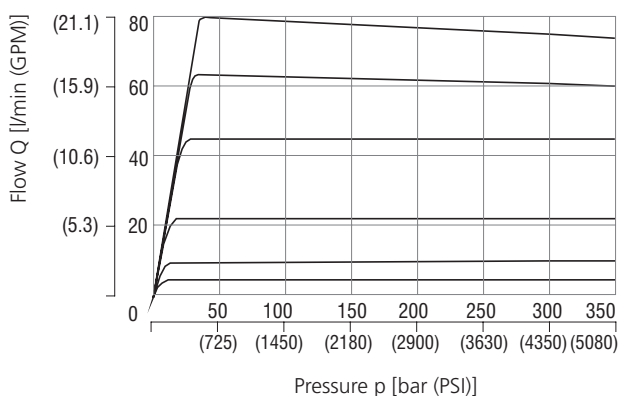

The characteristic of the pressure compensator corresponds to the flow rate of a PRM2-103Z11/60 proportional directional valve.

If the pressure resistance increases due to a flow rate increase, the pressure differential also has to increase in order to ensure correct regulation.

Dimensions in millimeters (inches)

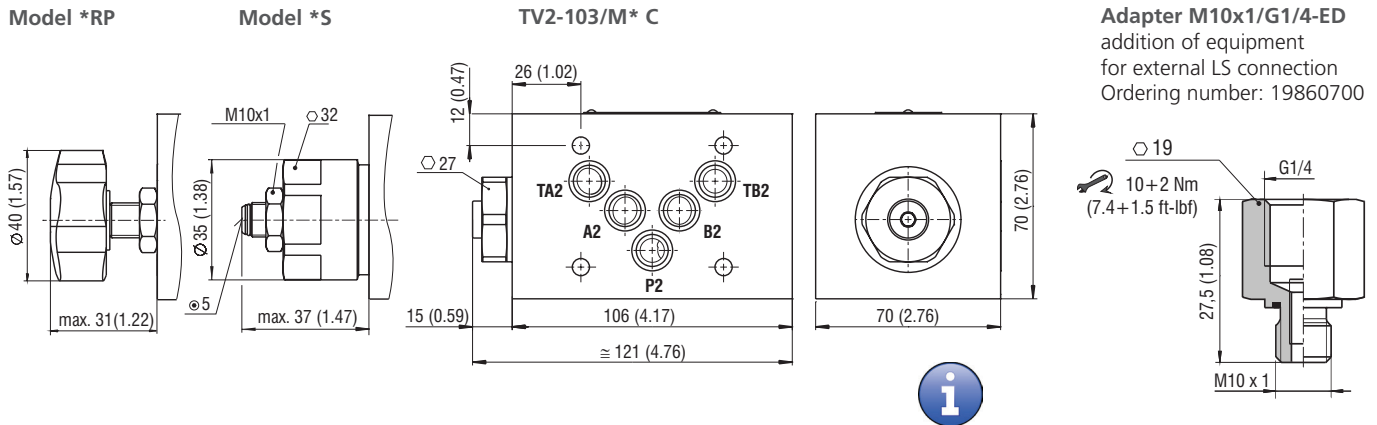

Adapter M10x1/G1/4-ED
 addition of equipment
 for external LS connection
 Ordering number: 19860700



Applicable only for „TV*C“ versions.
 (Fixed setting, not adjustable)

Application Example

Meter-in compensator

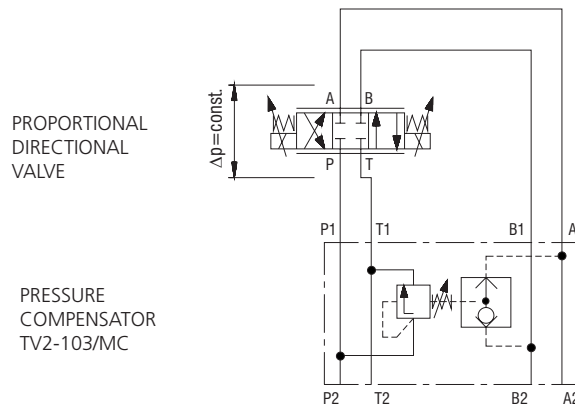

Functional Symbols

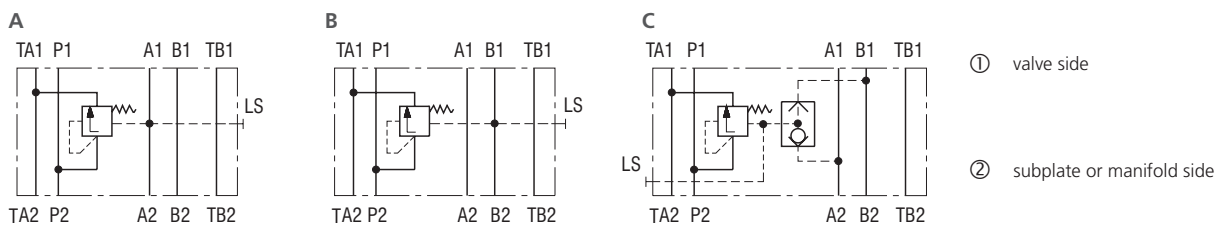

Notice: The orientation of the symbol on the name plate corresponds with the valve function.

Ordering Code

TV2-103 / M <input type="checkbox"/> <input type="checkbox"/> <input type="checkbox"/> <input type="checkbox"/> - <input type="checkbox"/>	
3-Way pressure compensator, spool-type, direct-acting, modular	Surface treatment
Sandwich plate	No designation housing phosphated, steel parts zinc-coated (ZnCr-3), ISO 9227 (240 h)
Model	A zinc-coated (ZnCr-3), ISO 9227 (240 h)
Meter-in compensator in channel A	B zinc-coated (ZnNi), ISO 9227 (520 h)
Meter-in compensator in channel B	Seals
Meter-in compensator in channel A and B	No designation
	V
	NBR
	FPM (Viton)
Control pressure differential	Adjustment option
4 - 12 bar (58 - 174 PSI), 10 bar (145 PSI) "C" Model	C fixed setting, not adjustable
10 - 14 bar (145 - 203 PSI), 14 bar (203 PSI) "C" Model	S allen key (hex. 5), without protective cap
	RP hand knob, plastic