

2-Way Pressure Compensator, Spool-Type, Direct-Acting, Modular

**TV2-102/M**

Size 10 (D05) •  $Q_{max}$  80 l/min (21 GPM) •  $p_{max}$  350 bar (5100 PSI)



**Technical Features**

- › 2-Way pressure compensator, spool-type, direct-acting with subplate interface acc. to ISO 4401, DIN 24340 (CETOP 05)
- › Modular design for vertical stacking assemblies with built-in load sensing shuttle valve
- › Meter-in flow control models with load sensing from optional consumer ports
- › The valve keeps the pressure drop between the inlet and the pilot connection at a constant level
- › Used as a load sensing valve with proportional directional and flow valves to control the flow rate independently of the pressure variations
- › Excellent stability throughout the flow range, rapid response to dynamic pressure changes
- › Adjustable by allen key or hand knob, or delivered with fix setting
- › Quiet and modulate response to load changes
- › Hardened precision parts
- › High flow capacity
- › In the standard version, the valve housing is phosphated and steel parts zinc-coated for 240 h protection acc. to ISO 9227

**Functional Description**

A normally open, direct-acting, spring loaded 2-way pressure compensator in the form of a sandwich plate. They consist of a body, a 2-way screw-in cartridge compensator TV2-102/S and a load shuttle valve.

**2-Way compensators for meter-in applications (models A,B,C)**

The 2-way meter-in pressure compensators will maintain a constant pressure difference across the metering edge of the proportional directional valve. In this case, the pressure variations due to load changes, as well as pump pressure changes are compensated. Any increase in pump pressure does not affect the flow. The meter-in compensators may only be used with positive load direction. They are designated for load compensation in inlet port P.

**2-Way compensators for meter-out applications (models D,E,F)**

In systems with changing load directions or negative load, the use of meter-out pressure compensators is required. With respect to the application, a valve with pressure compensator installed in one or in both actuator ports are available. The pressure compensator is always mounted between the actuator and the proportional directional valve. The valve will maintain the pressure difference between A and T or B and T constant. The flow rate and the flow direction are adjusted by the proportional directional valve. To enable free reverse flow, two by-pass check valves are incorporated into the valve body.

ISO 4401-05-04-0-05

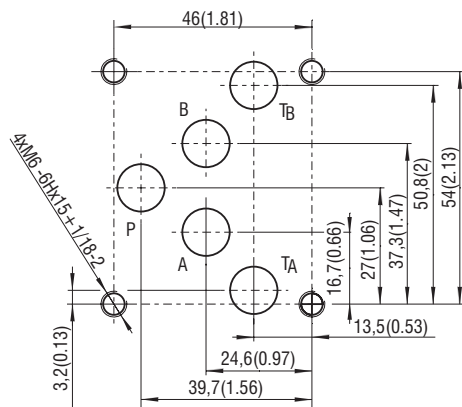

Ports P, A, B, T - max.  $\varnothing$ 11.2 mm (0.44 in)

**Technical Data**

Valve size		10 (D05)
Max. operating pressure	bar (PSI)	350 (5100)
Max. flow	l/min (GPM)	80 (21.1)
Control pressure differential	bar (PSI)	4... 14 (58...203)
Fluid temperature range (NBR)	$^{\circ}$ C ( $^{\circ}$ F)	-30... +100 (-22... +212)
Fluid temperature range (FPM)	$^{\circ}$ C ( $^{\circ}$ F)	-20... +120 (-4... +248)
Mass (Models A, B, C / D, E, F)	kg (lbs)	3.7 (8.2) / 6.65 (14.7)

	Data Sheet	Type
General information	GI_0060	Products and operating conditions
Mounting interface	SMT_0019	Size 10
Spare parts	SP_8010	

**Characteristics** measured at  $v = 32 \text{ mm}^2/\text{s}$  (156 SUS)

**Regulated flow related to input pressure**

TV2-102/MC Meter-in compensator

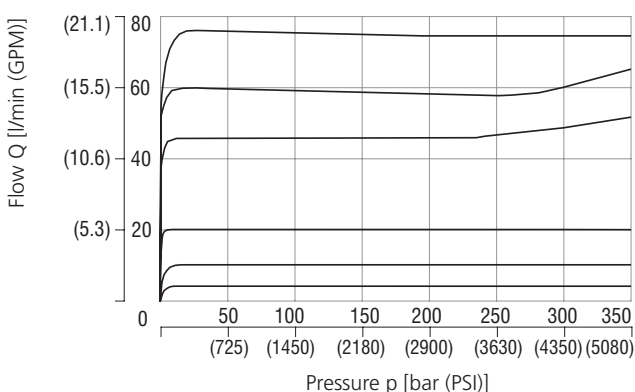

TV2-102/MD Meter-out compensator

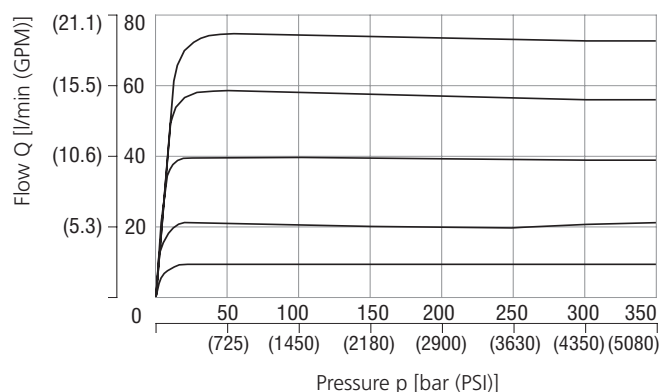

The characteristic of the pressure compensator corresponds to the flow rate of a PRM2-103Z11/60 proportional directional valve. If the pressure resistance increases due to a flow rate increase, the pressure differential also has to increase in order to ensure correct regulation.

## Dimensions in millimeters (inches)

### TV2-102/MC\*C Meter-in compensator

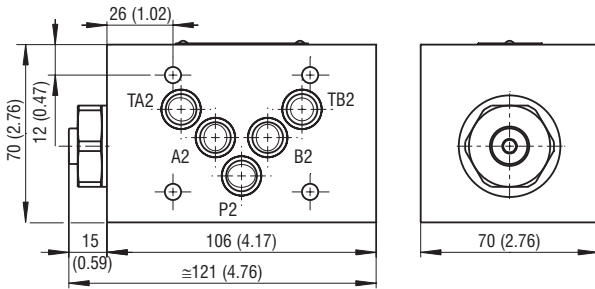

**Adapter M10x1/G1/4-ED**  
 addition of equipment  
 for external LS connection  
 Ordering number: 19860700

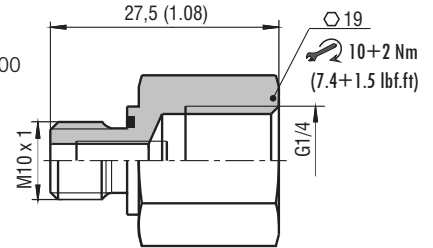

Applicable only for „TV\*C“ versions. (Fixed setting, not adjustable)

### TV2-102/MD\*C Meter-out compensator

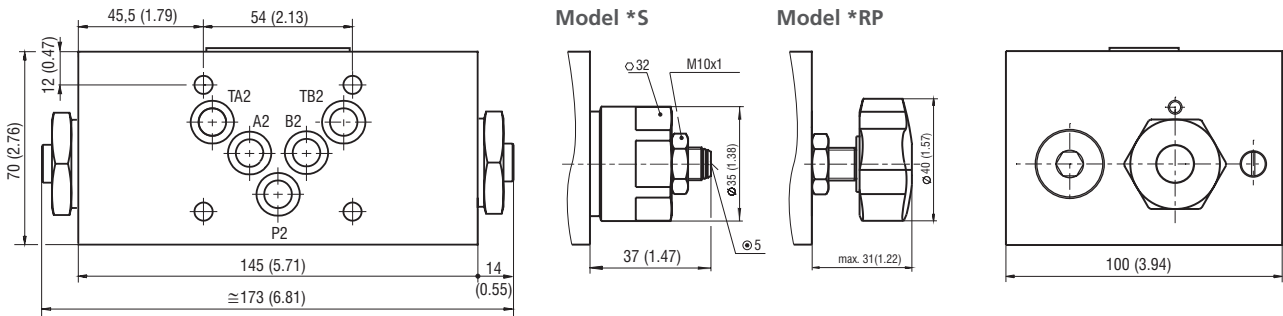

## Application Example

### Meter-in compensator

SHUTTLE VALVE  
 PROPORTIONAL DIRECTIONAL VALVE  
 PRESSURE COMPENSATOR

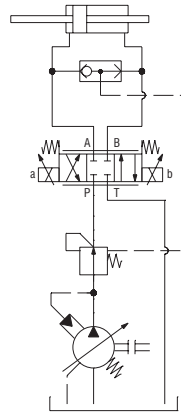

### Meter-out compensator

PRESSURE COMPENSATOR  
 PROPORTIONAL DIRECTIONAL VALVE

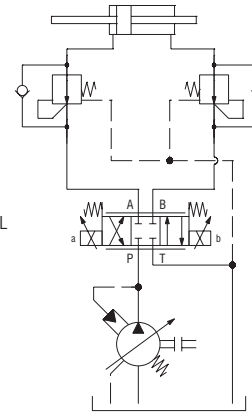

## Functional Symbols

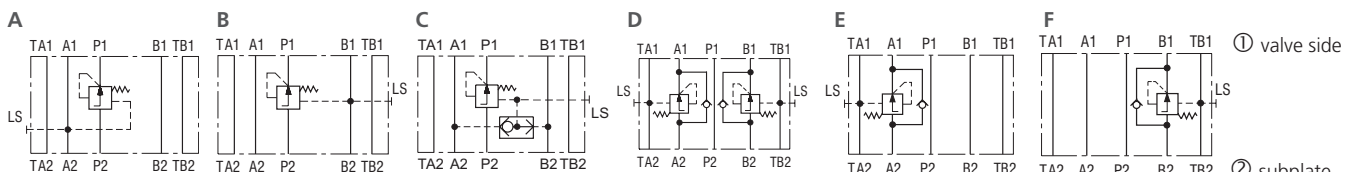

**Notice:** The orientation of the symbol on the name plate corresponds with the valve function.

## Ordering Code

<b>2-Way pressure compensator, spool-type, direct-acting, modular</b>	TV2-102/M							
<b>Sandwich plate</b>								
<b>Model</b>								
Meter-in compensator in channel A	A							
Meter-in compensator in channel B	B							
Meter-in compensator in channel A and B	C							
Meter-out compensator in channel A and B	D							
Meter-out compensator in channel A	E							
Meter-out compensator in channel B	F							
<b>Control pressure differential</b>								
4 - 12 bar (58 - 174 PSI), 10 bar (145 PSI) "C" Model	1							
10 - 14 bar (145 - 203 PSI), 14 bar (203 PSI) "C" Model	2							
<b>Surface treatment</b>								
No designation								housing phosphated, steel parts zinc-coated (ZnCr-3), ISO 9227 (240 h)
A								zinc-coated (ZnCr-3), ISO 9227 (240 h)
B								zinc-coated (ZnNi), ISO 9227 (520 h)
<b>Seals</b>								
No designation								NBR
V								FPM (Viton)
<b>Adjustment option</b>								
No designation								fixed setting, non adjustable
C								allen key (hex. 5), without protective cap
S								hand knob, plastic
RP								