

## 2-Way Pressure Compensator, Spool-Type, Direct-Acting, Modular

# TV2-042/M

Size 04 (D02) •  $Q_{max}$  16 l/min (4 GPM) •  $p_{max}$  320 bar (4600 PSI)



### Technical Features

- › 2-Way pressure compensator, spool-type, direct-acting with subplate interface acc. to ISO 4401, DIN 24340 (CETOP 02)
- › Modular design for vertical stacking assemblies with built-in load sensing shuttle valve
- › Meter-in and meter-out flow control models with integrated by-pass check valves
- › The valve keeps the pressure drop between the inlet and the pilot connection at a constant level
- › Used as a load sensing valve with proportional directional and flow valves to control the flow rate independently of pressure variations
- › Excellent stability throughout the flow range, rapid response to dynamic pressure changes
- › Quiet and modulate response to load changes
- › Hardened precision parts
- › High flow capacity
- › In the standard version, the valve housing is phosphated and steel parts are zinc-coated

ISO 4401-02-01-0-05

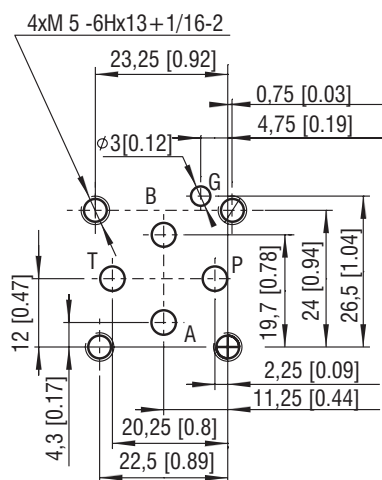

Ports P, A, B, T - max  $\varnothing$  4.5 mm (0.18 in)

### Functional Description

A normally open, direct-acting, spring loaded 2-way pressure compensator in the form of a sandwich plate.

#### 2-Way compensators for meter-in applications (models A,B,C)

The 2-way meter-in pressure compensators will maintain a constant pressure difference across the metering edge of the proportional directional valve. In this case, the pressure variations due to load changes as well as pump pressure changes are compensated. Any increase in pump pressure does not affect the flow. The meter-in compensators may only be used with positive load direction.

They are designated for load compensation in inlet port P.

#### 2-Way compensators for meter-out applications (models D,E,F)

In systems with changing load directions or negative load, the use of meter-out pressure compensators is required. With respect to the application, a valve with a pressure compensator installed in one or in both actuator ports are available.

The pressure compensator is always mounted between the actuator and the proportional directional valve. The valve will maintain the pressure difference between A and T or B and T constant.

The flow rate and the flow direction are adjusted by the proportional directional valve.

To enable free reverse flow, two by-pass check valves are incorporated into the valve body.

### Technical Data

Valve size		04 (D02)
Max. operating pressure	bar (PSI)	320 (4640)
Max. flow	l/min (GPM)	16 (4.2)
Control pressure differential	bar (PSI)	10 (145)
Fluid temperature range (NBR)	°C (°F)	-30 .... +100 (-22 ... +212)
Fluid temperature range (FPM)	°C (°F)	-20 .... +120 (-4 ... +248)
Mass (all models)	kg (lbs)	0.6 (1.32)

	Data Sheet	Type
General information	GI_0060	Products and operating conditions
Mounting interface / tolerances	SMT_0019	Size 04
Spare parts	SP_8010	

### Characteristics measured at $v = 32 \text{ mm}^2/\text{s}$ (156 SUS)

#### Regulated flow related to input pressure

TV2-042/MC Meter-in compensator

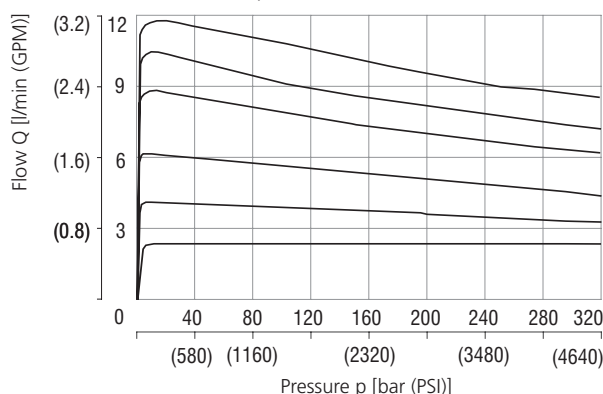

TV2-042/MD Meter-out compensator

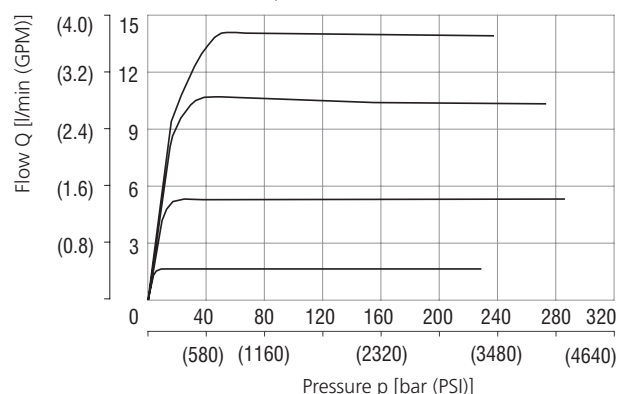

The characteristic of the pressure compensator corresponds to the flow rate of a PRM2-043Z11/12 proportional directional valve. If the pressure resistance increases due to a flow rate increase, the pressure differential also has to increase in order to ensure correct regulation.

**Dimensions** in millimeters (inches)

**TV2-042/MA (B, C) Meter-in compensator**

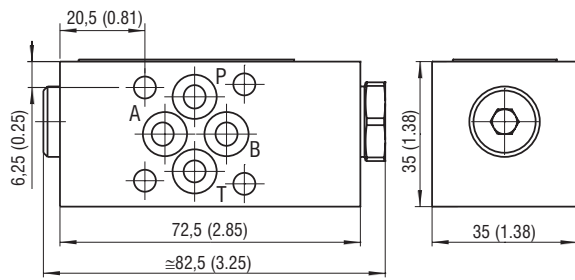

**TV2-042/MD (E, F) Meter-out compensator**

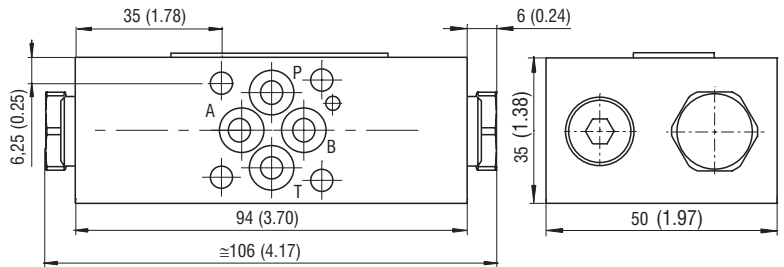

**Application Example**

**TV2-042/MC Meter-in compensator**

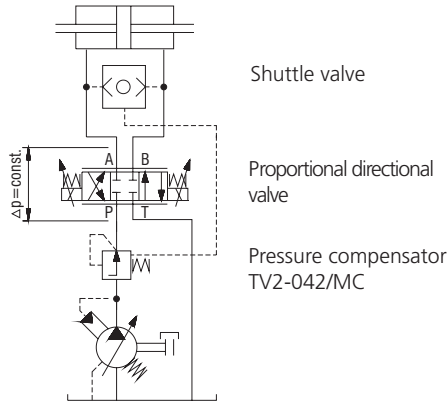

**TV2-042/MD Meter-out compensator**

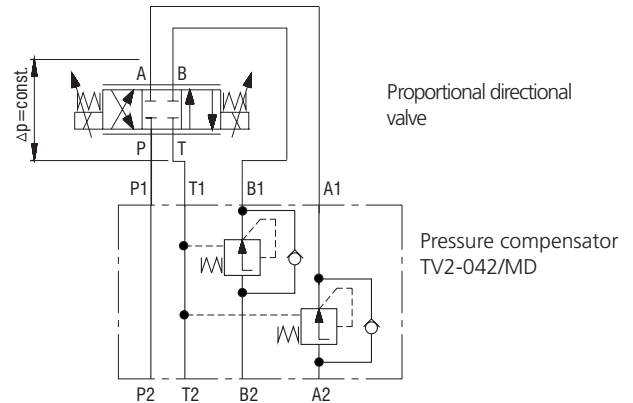

**Functional Symbols**

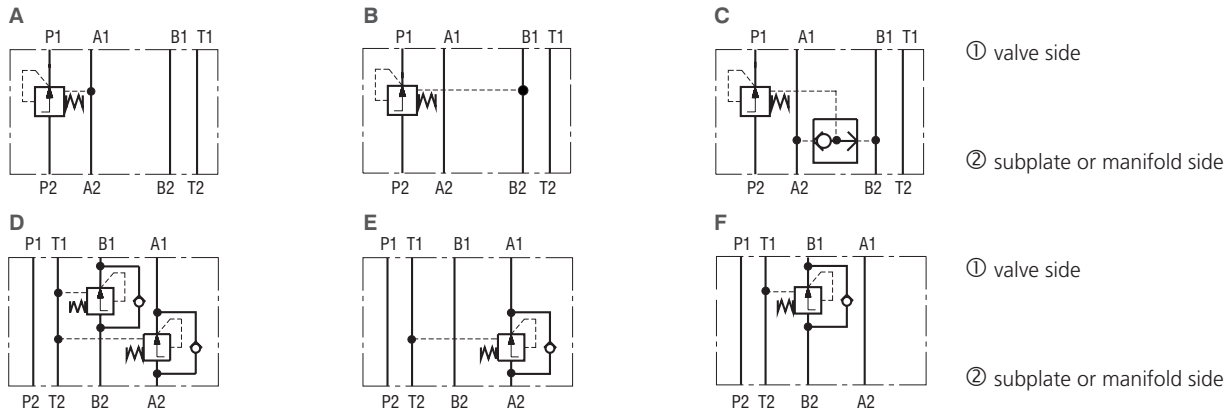

**Notice:** The orientation of the symbol on the name plate corresponds with the valve function.

**Ordering Code**

