

Proportional Pressure Control Valve, Relieving, Pilot Operated, Inverted

SRN4P1-B2

7/8-14 UNF • Q_{max} 80 l/min (21 GPM) • p_{max} 350 bar (5100 PSI)

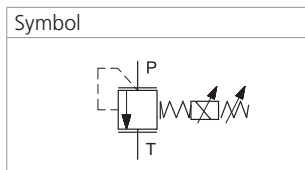
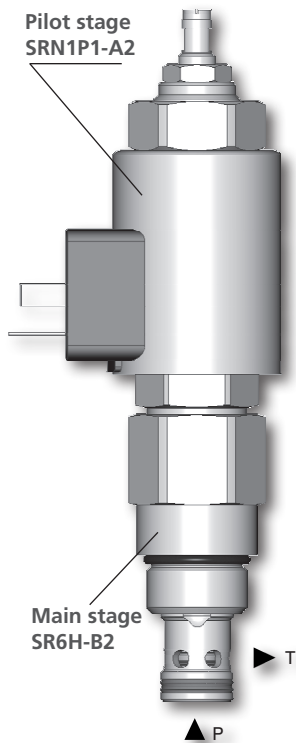

Technical Features

- › Decreasing pressure output proportional with increasing DC current input
- › Low hysteresis, accurate pressure control and low pressure drop
- › Wide pressure range up to 350 bar
- › Mechanical adjustment of minimum cracking pressure
- › High flow capacity
- › Solenoid electrical terminal option acc. to EN 175301-803-A, AMP Junior Timer, or Deutsch DT04-2P
- › 12 or 24 V DC coils
- › In the standard version, the valve is zinc-coated for 240 h protection acc. to ISO 9227

Functional Description

A pilot operated proportional pressure relief spool valve in the form of a screw-in cartridge. The valve is designed for continuous regulation of system pressure. The complete valve consist of pilot stage SRN1P1-A2 and main stage with connection 7/8-14 UNF. To set the minimum cracking pressure use the adjusting screw (s=5) which incorporates also the air bleed screw. Back pressure on port T becomes additive to the pressure setting of the valve. Air bleeding is necessary for the correct function of the valve.
 Installation: When possible, the valve should be mounted below the reservoir oil level. This will keep oil in the actuator at all times, preventing instability caused by air enclosures. If this is not possible, mount the valve for best results vertically downward with proper air bleeding.

Technical Data

Valve size / Cartridge cavity		7/8-14 UNF-2A / B2 (C-10-2)	
Max. operating pressure (port P)	bar (PSI)	350 (5080)	
Max. operating pressure (port T)	bar (PSI)	100 (1450)	
Max. flow	l/min (GPM)	80 (21.1)	
Fluid temperature range (NBR)	°C (°F)	-30...+120 (-22...+248)	
Fluid temperature range (FPM)	°C (°F)	-20...+120 (-4...+248)	
Ambient temperature range	°C (°F)	-30...+80 (-22...+176)	
Min. setting pressure	bar (PSI)	7 bar (101.5 PSI) for 5 l/min (1.32 GPM)	
Hysteresis	%	< 5	
Solenoid data			
Supply voltage	V	12 DC	24 DC
Max. current	A	1	0.6
Rated resistance at 20 °C (68 °F)	Ω	6.5±5 %	20.6±5 %
Duty cycle	%	100	
Optimal PWM frequency	Hz	250	
Quenching diode		BZW06-19B	BZW06-33B
Enclosure type acc. to EN 60529**		(acc.to terminal type) IP65 / IP67 / IP69K	
Weight with solenoid	kg (lbs)	0.58 (1.28)	
	Data Sheet	Type	
General information			
	GI_0060	Products and operating conditions	
Coil types	C_8007	C19B*	
Valve bodies	In-line mounted	SB_0018	SB-B2*
Cavity details / Form tools	SMT_0019	SMT-B2*	
Spare parts	SP_8010		

**The indicated IP protection level is only reached with a properly mounted connector.

Dimensions in millimeters (inches)

Connector type

E1, E2 - IP65
EN 175301-803-A

E3, E4 - IP67
AMP Junior Timer
- radial

E3A, E4A - IP67
AMP Junior Timer
- axial

E12A, E13A
- IP67 / IP69K
Deutsch DT04-2P

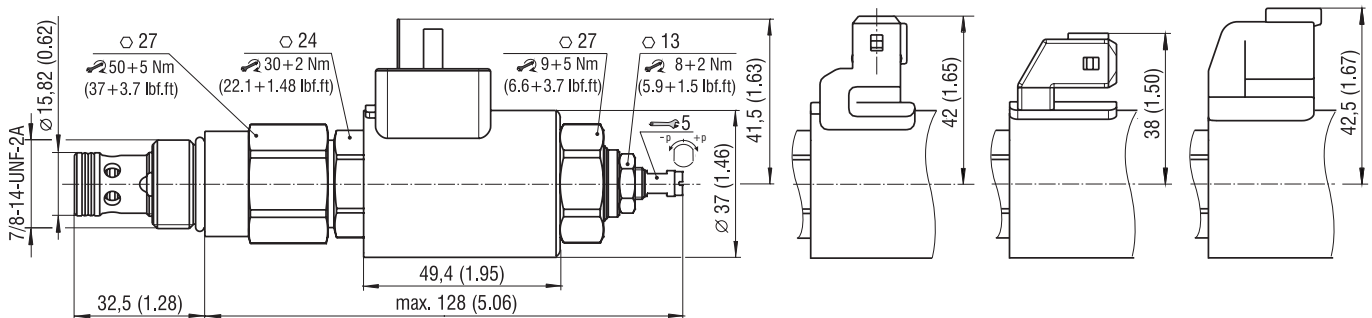

Characteristics measured at $v = 32 \text{ mm}^2/\text{s}$ (156 SUS)

Relief pressure related to control signal

Q=5 l/min (1.32 GPM), pressure in port T=0 bar, PWM 160 Hz

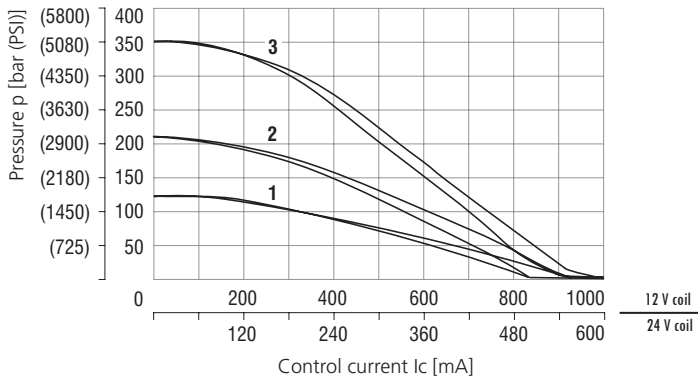

Pressure range	12	21	35
	1	2	3

Relief pressure related to flow rate

Pressure range 35, various control currents

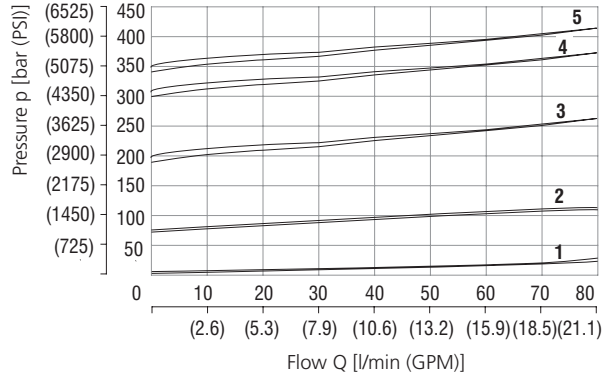

Control current	1	2	3	4	5
	100 % I _{max}	75 % I _{max}	25 % I _{max}	25 % I _{max}	0 % I _{max}

Pressure drop related to flow rate

100 % of control current, P-T direction

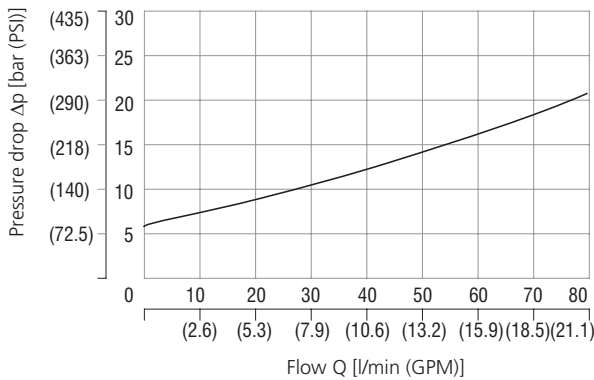

Ordering Code

SRN4P1 - B2 / H [] - [] [] [] - []

Proportional pressure control valve, relieving, pilot operated, inverted

Valve cavity
7/8-14 UNF-2A (C-10-2)

Model
High performance

Max. regulated pressure

up to 120 bar (1740 PSI)	12
up to 210 bar (3046 PSI)	21
up to 350 bar (5076 PSI)	35

Supply voltage / max. current

12 V DC / 1.0 A	12
24 V DC / 0.6 A	24

Main stage ordering key: SR6H-B2/HV

Surface treatment

A zinc-coated (ZnCr-3), ISO 9227 (240 h)

B zinc-coated (ZnNi), ISO 9227 (520 h)

No designation

V

Seals
NBR
FPM (Viton)

Connector type
EN 175301-803-A

E1 E1 with quenching diode

E2 AMP Junior Timer - radial direction (2 pins; male)

E3 E3 with quenching diode

E4 AMP Junior Timer - axial direction (2 pins; male)

E3A E3A with quenching diode

E4A E4A with quenching diode

E12A Deutsch DT04-2P - axial direction

E13A E12A with quenching diode

For other solenoid terminals see data sheet No. 8007