



205 SERIES STG

BSP / NPTF
DIN3852 / SAE



Poppet valve closing system
BSP, NPTF, DIN2353, DIN3852, SAE/ORB and other threads upon request.
AISI 316 available only by minimum quantities.

• Materials

Carbon Steel *EN -10277-3 / AISI 316L*

O-ring: **NBR, Viton or EPDM**

Back-up-ring: **PTFE**

Springs: *Carbon Steel DIN 17233/84(B)*

• Working temperature (O-ring)

	NBR	Viton	EPDM
+	+100°C	+200°C	+150°C
-	-30°C	-10°C	-40°C

• **Applications:** Designed for Oil hydraulic Applications
Hammer Application

• **Sectors:** Industrial, Agricultural, Construction machinery.



• Equivalence

FASTER CVV
ARGUS HD
VOSWINKEL HS

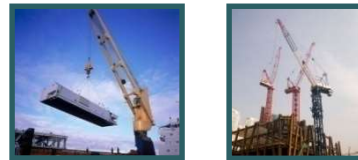

MODEL STRUCTURE

Example:

205.12115 AF

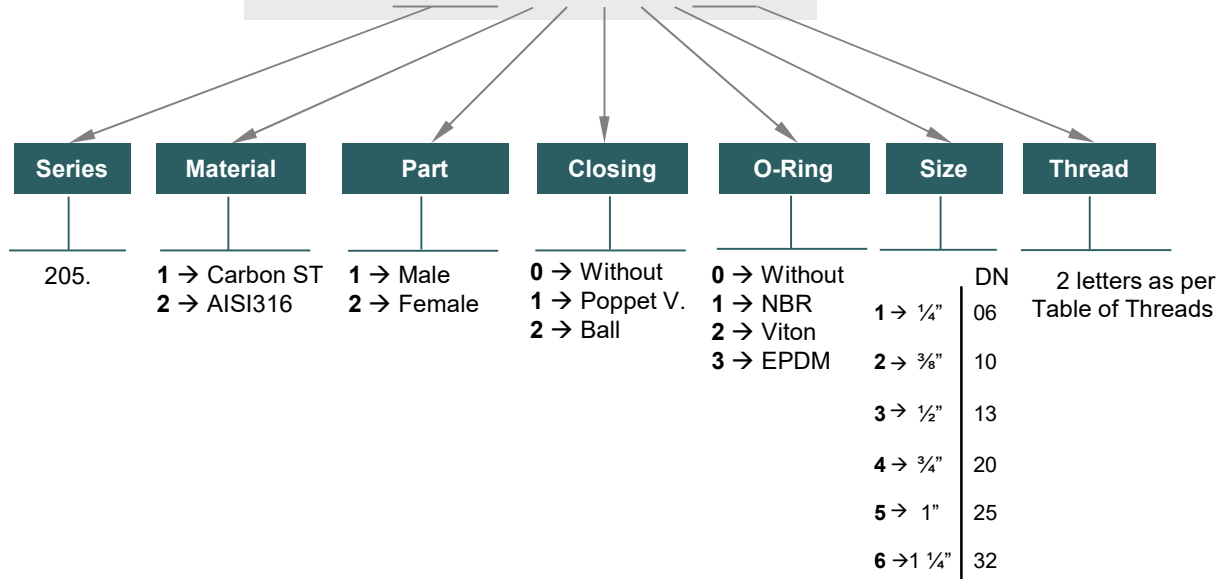

205-1





205 SERIES STG

BSP / NPTF
DIN3852 / SAE



MALE					
DN	CH1	CH2	C	ØD	L
06	19	30	59,50	34	94
10	22	36	61,10	34	98
13	27	41	67,30	41,80	112
20	36	50	81	48	140
25	41	55	87,5	59,80	152
32	60	75	124	79,80	241,80

FEMALE					
DN	CH1	CH2	C	ØA2	L
06	19	24	60	Rd 24x2	94
10	22	30	64	Rd 28x2	98
13	27	36	73	Rd 36x2	112
20	36	42	91	Rd 42x2	140
25	41	50	100	Rd 48x3	152
32	55	60	150	Rd 70x3	241,80

STANDARD MODELS			
DN	ØA	MALE	FEMALE
06	1/4" BSP	205.11111AB	205.12111AB
	1/4" NPTF	205.11111BB	205.12111BB
	M14x1,5	205.11111NC	205.12111NC
10	1/4" BSP	205.11112AB	205.12112AB
	3/8" BSP	205.11112AC	205.12112AC
	3/8" NPTF	205.11112BC	205.12112BC
13	M16x1,5	205.11112ND	205.12112ND
	3/8" BSP	205.11113AC	205.12113AC
	1/2" BSP	205.11113AD	205.12113AD
20	1/2" NPTF	205.11113BD	205.12113BD
	M18x1,5	205.11113NE	205.12113NE
	M22x1,5	205.11113NG	205.12113NG
25	3/4" -16ORB	205.11113GF	205.12113GF
	7/8" -14ORB	205.11113GH	205.12113GH
	3/4" BSP	205.11114AE	205.12114AE
32	3/4" NPTF	205.11114BE	205.12114BE
	M22x1,5	205.11114NG	205.12114NG
	3/4" BSP	205.11115AE	205.12115AE
06	1" BSP	205.11115AF	205.12115AF
	1" NPTF	205.11115BF	205.12115BF
	1 1/4" BSP	205.11116AG	205.12116AG
10	1 1/4" NPTF	205.11116BG	205.12116BG
	1 1/2" BSP	205.11116AH	205.12116AH
	1 1/2" NPTF	205.11116BH	205.12116BH



205 SERIES STG

BSP / NPTF
DIN3852 / SAE



TECHNICAL DATA

DN	Rated Flow	Min Burst Pressure (bar)			Max. Working Pressure
		Male	Female	Coupled	
06	12 l/m	1580	1500	1800	500 Bar
10	32 l/m	1750	1680	1800	450 Bar
13	75 l/m	1580	1500	1600	400 Bar
20	145 l/m	1520	1400	1600	400 Bar
25	255 l/m	1200	1150	1200	350 Bar
32	440 l/m	1450	1520	1650	410 Bar

Test performed according to ISO 18869

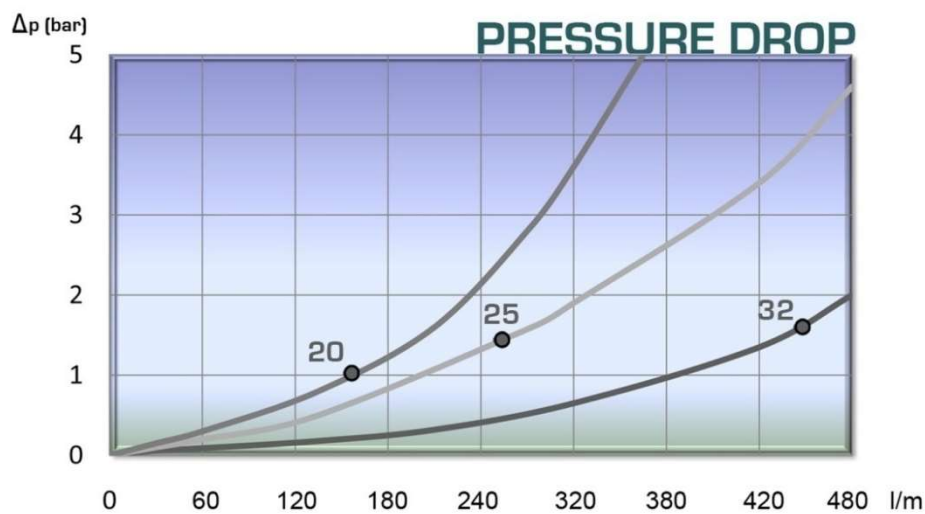
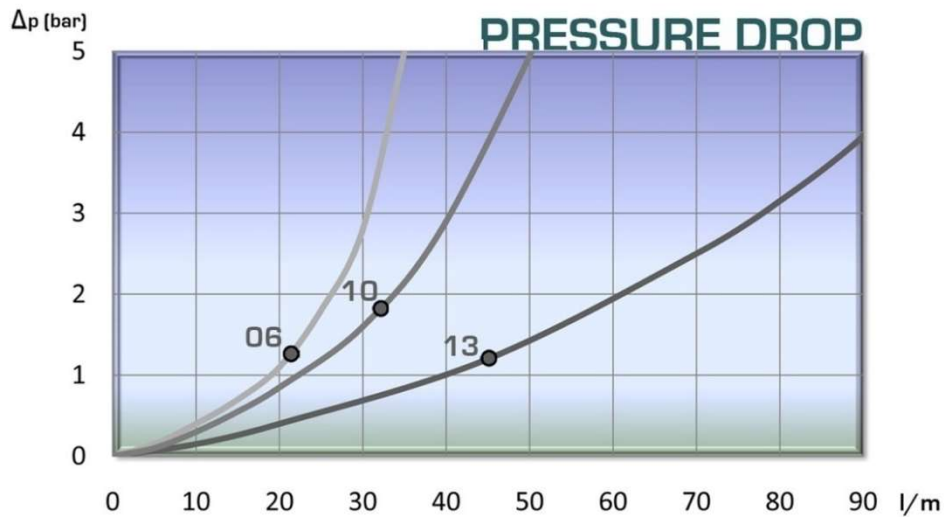



205 SERIES

STG

DIN2353

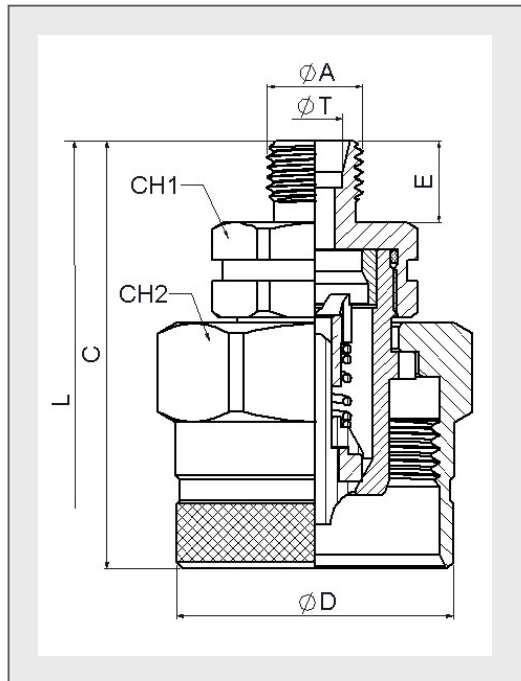

STANDARD MALE MODELS										
DN	ØA	ØT	REF.		CH1	CH2	C	ØD	E	L
06	M12x1,5	6L	205.11111JB	450Bar	19	30	58,5	29,5	10	91,3
	M14x1,5	8L	205.11111JC							
	M18x1,5	12L	205.11112JE							
10	M14x1,5	8L	205.11112JC	450Bar	22	36	62,1	34	12	96
	M16x1,5	10L	205.11112JD							
	M16x1,5	8S	205.11112KD							
	M18x1,5	10S	205.11112KE							
	M20x1,5	12S	205.11112KF							
	M14x1,5	8L	205.11113JC							
13	M16x1,5	10L	205.11113JD	400Bar	27	41	63,30	40,50	12	101
	M18x1,5	12L	205.11113JE							
	M22x1,5	15L	205.11113JG							
	M26x1,5	18L	205.11113JI							
	M18x1,5	10S	205.11113KE							
	M20x1,5	12S	205.11113KF							
	M22x1,5	14S	205.11113KG							
	M24x1,5	16S	205.11113KH							
	M18x1,5	12L	205.11114JE							
	M22x1,5	15L	205.11114JG							
20	M26x1,5	18L	205.11114JI	400Bar	36	41	78	48	18	124
	M30x2	22L	205.11114JJ							
	M22x1,5	14S	205.11114KG							
	M24x1,5	16S	205.11114KH							
	M30x2	20S	205.11114KJ							
	M26x1,5	18L	205.11115JI							
25	M30x2	22L	205.11115JJ	300Bar	41	55	70,50	59,80	16	146
	M36x2	28L	205.11115JK							
	M45x2	35L	205.11115JM							
	M30x2	20S	205.11115KJ							
	M36x2	25S	205.11115KK							
	M42x2	30S	205.11115KL							
	M52x2	38S	205.11115KN							
	M42x2	30S	205.11116KL							
32	M42x2	30S	205.11116KL	410Bar	50	75	143	79,80	20	243,80
	M52x2	38S	205.11116KN							

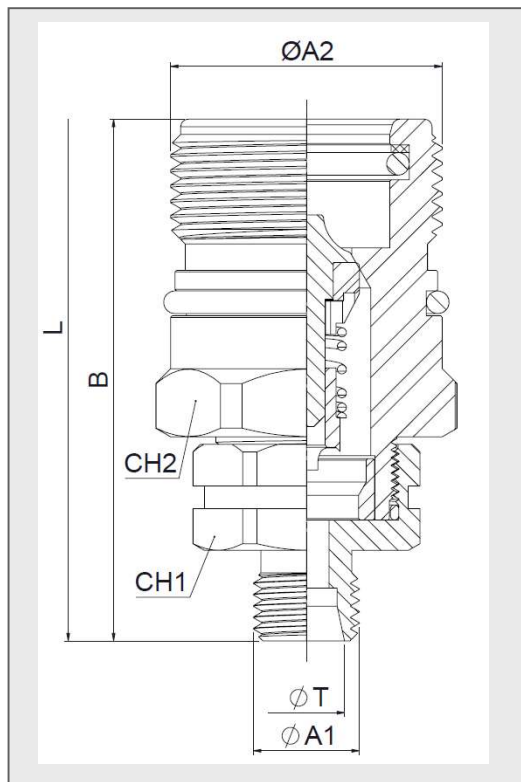

STANDARD FEMALE MODELS										
DN	ØA	ØT	REF.		CH1	CH2	B	ØA2	E	L
06	M12x1,5	6L	205.12111JB	450Bar	19	24	59	Rd 24x2	10	91,3
	M14x1,5	8L	205.12111JC							
	M18x1,5	12L	205.12112JE							
10	M14x1,5	8L	205.12112JC	450Bar	22	24	63	Rd 28x2	12	96
	M16x1,5	10L	205.12112JD							
	M16x1,5	8S	205.12112KD							
	M18x1,5	10S	205.12112KE							
	M20x1,5	12S	205.12112KF							
	M14x1,5	8L	205.12113JC							
13	M16x1,5	10L	205.12113JD	400Bar	27	32	66	Rd 36x2	12	101
	M18x1,5	12L	205.12113JE							
	M22x1,5	15L	205.12113JG							
	M26x1,5	18L	205.12113JI							
	M18x1,5	10S	205.12113KE							
	M20x1,5	12S	205.12113KF							
	M22x1,5	14S	205.12113KG							
	M24x1,5	16S	205.12113KH							
	M18x1,5	12L	205.12114JE							
	M22x1,5	15L	205.12114JG							
20	M26x1,5	18L	205.12114JI	400Bar	36	36	84	Rd 42x2	18	131
	M30x2	22L	205.12114JJ							
	M22x1,5	14S	205.12114KG							
	M24x1,5	16S	205.12114KH							
	M30x2	20S	205.12114KJ							
	M26x1,5	18L	205.12115JI							
25	M30x2	22L	205.12115JJ	300Bar	41	41	97	Rd 48x3	16	146
	M36x2	28L	205.12115JK							
	M45x2	35L	205.12115JM							
	M30x2	20S	205.12115KJ							
	M36x2	25S	205.12115KK							
	M42x2	30S	205.12115KL							
	M52x2	38S	205.12115KN							
	M42x2	30S	205.12116KL							
32	M42x2	30S	205.12116KL	410Bar	55	60	151	Rd 70x3	20	243,80
	M52x2	38S	205.12116KN							

205 SERIES

STG

DIN2353



STANDARD MALE MODELS

DN	ØA	ØT	REF.		CH1	CH2	CH3	C	ØD	E	L
06	M12x1,5	6L	205.11111LB	450Bar	19	30	19	73,5	29,5	24	121,3
	M14x1,5	8L	205.11111LC				17	80,50		34	135,3
	M14x1,5	8L	205.11112LC				19	81,50		34	151,50
10	M16x1,5	10L	205.11112LD	450Bar	22	30	22	65,20	34	26	127,50
	M16x1,5	8S	205.11112MD				24	75,20		27	138,20
	M18x1,5	10S	205.11112ME				22				
13	M20x1,5	12S	205.11112MF	400Bar	27	36	27		41,80	34	156,50
	M14x1,5	8L	205.11113LC				19	85,50		35	157,50
	M16x1,5	10L	205.11113LD				22	86,50		24	136,50
	M18x1,5	12L	205.11113LE				24	75,50		24	136,50
	M22x1,5	15L	205.11113LG				27			33	157,50
	M26x1,5	18L	205.11113LI				30	86,50		24	136,50
	M18x1,5	10S	205.11113ME				24	75,50		35	157,50
	M20x1,5	12S	205.11113MF				22			24	136,50
	M22x1,5	14S	205.11113MG				27	86,50		35	157,50
20	M24x1,5	16S	205.11113MH	400Bar	36	41	30		48	26	157
	M18x1,5	12I	205.11114LE				24	86		33	171
	M22x1,5	15L	205.11114LG				27	93		34	173
	M26x1,5	18L	205.11114LI				30	93		29	173
	M30x2	22L	205.11114LJ				36	94		36	163
	M24x1,5	16S	205.11114MH				30	89		33	185,50
	M30x2	20S	205.11114MJ				36	96		34	187,50
	M26x1,5	18L	205.11115LI				30	99,50		33	185,50
	M30x2	22L	205.11115LJ				36	100,50		34	187,50
25	M36x2	28L	205.11115LK	300Bar	41	55	41	100,50	59,80	36	191,50
	M45x2	35L	205.11115LM				55	102,50		35	189,50
	M30x2	20S	205.11115MJ				36	101,50		38	195,50
	M36x2	25S	205.11115MK				41	104,50		40	199,50
	M42x2	30S	205.11115ML				50	106,50		40	199,50
	M52x2	38S	205.11115MN				65				284
32	M42x2	30S	205.11116ML	410Bar	50	75	50	143	40	284	

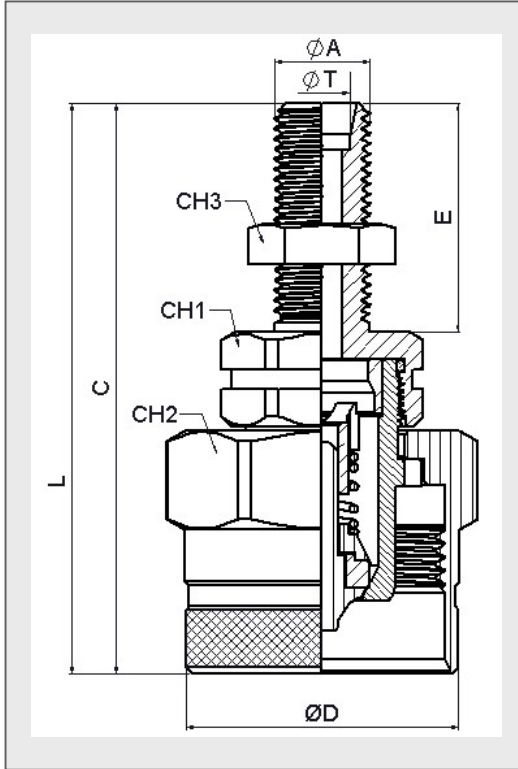

STANDARD FEMALE MODELS

DN	ØA	ØT	REF.		CH1	E/C	CH3	B	ØA1	E	L
06	M12x1,5	6L	205.12111LB	450Bar	19	24	19	74	Rd 24x2	24	121,3
	M14x1,5	8L	205.12111LC				17	81		34	135,3
	M14x1,5	8L	205.12112LC				19	85		34	151,50
10	M16x1,5	10L	205.12112LD	450Bar	22	24	22	77	Rd 28x2	26	127,50
	M16x1,5	8S	205.12112MD				24	780		27	138,20
	M18x1,5	10S	205.12112ME				22				
13	M20x1,5	12S	205.12112MF	400Bar	27	32	27		Rd36x2	34	156,50
	M14x1,5	8L	205.12113LC				19	88		35	157,50
	M16x1,5	10L	205.12113LD				22	89		24	136,50
	M18x1,5	12L	205.12113LE				24	78		24	136,50
	M22x1,5	15L	205.12113LG				27			35	157,50
	M26x1,5	18L	205.12113LI				30	89		24	136,50
	M18x1,5	10S	205.12113ME				24	78		35	157,50
	M20x1,5	12S	205.12113MF				22			24	136,50
	M22x1,5	14S	205.12113MG				27	88		35	157,50
20	M24x1,5	16S	205.12113MH	400Bar	36	36	30		Rd 42x2	26	157
	M18x1,5	12I	205.12114LE				24	92		33	171
	M22x1,5	15L	205.12114LG				27	93		34	173
	M26x1,5	18L	205.12114LI				30	93		29	173
	M30x2	22L	205.12114LJ				36	99		36	163
	M24x1,5	16S	205.12114MH				30	100		33	185,50
	M30x2	20S	205.12114MJ				36	95		34	187,50
	M26x1,5	18L	205.12115LI				30	112		33	185,50
	M30x2	22L	205.12115LJ				36	113		34	187,50
25	M36x2	28L	205.12115LK	300Bar	41	41	41	113	Rd 48x3	36	191,50
	M45x2	35L	205.12115LM				55	115		35	189,50
	M30x2	20S	205.12115MJ				36	114		38	195,50
	M36x2	25S	205.12115MK				41	117		40	199,50
	M42x2	30S	205.12115ML				50	119		40	199,50
	M52x2	38S	205.12115MN				65				284
32	M42x2	30S	205.12116ML	410Bar	50	60	50	171	Rd 70x3	40	284

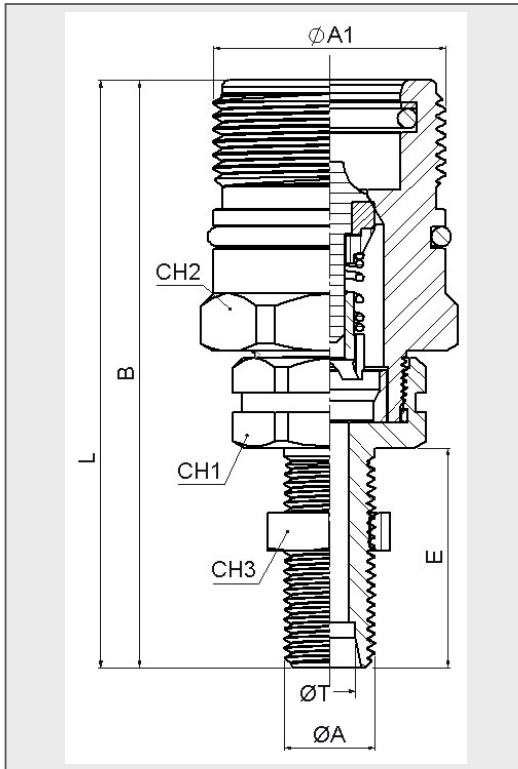

205-5

INTEVA reserves the right to make modifications in its products without prior notice. Any external or internal alteration in our products will automatically void the warranty.





205 SERIES STG

PLUGS
& CAPS



STG SERIES PLUGS, CAPS and have been designed to protect FEMALE (coupler) or MALE (nipple) parts while they are disconnected.

MODEL STRUCTURE

Example:

205.5414 AA

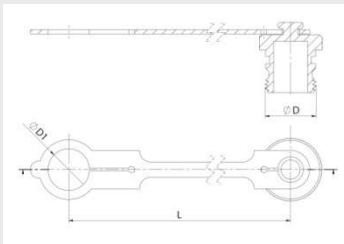
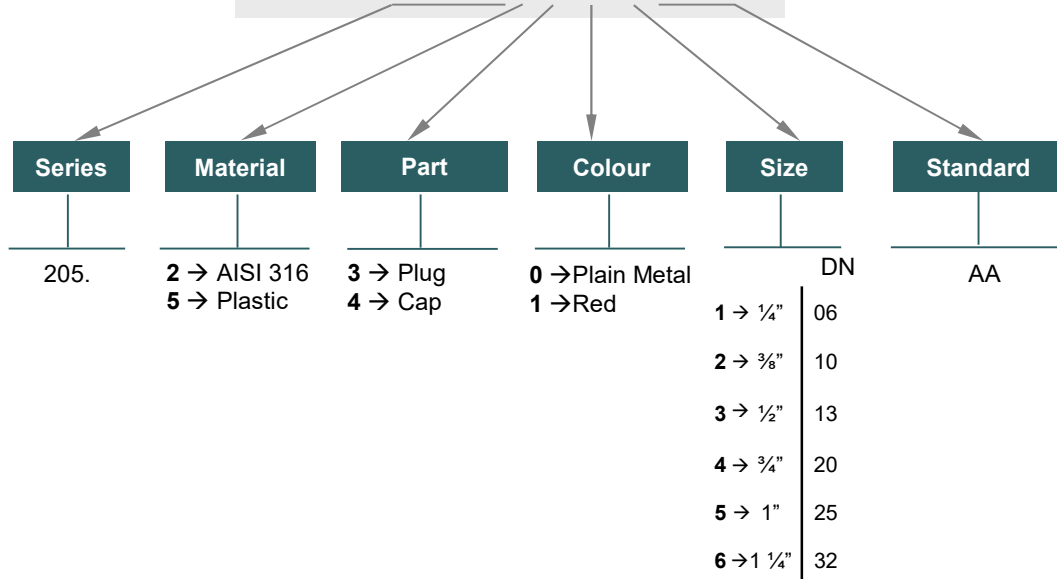

PLUG

DN	REF.	ØD	ØD1	L
06	205.5311AA	Rd 24x2	20	90
10	205.5312AA	Rd 28x2	24	100
13	205.5313AA	Rd 36x2	29,50	135
20	205.5314AA	Rd 42x2	37	187
25	205.5315AA	Rd 48x3	41	145
32	205.5316AA	Rd 70x3	55	200

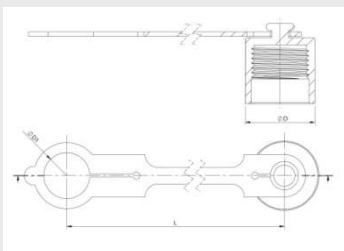

CAP

DN	REF.	ØD	ØD1	L
06	205.5411AA	Rd 24x2	20	90
10	205.5412AA	Rd 28x2	24	100
13	205.5413AA	Rd 36x2	29,50	135
20	205.5414AA	Rd 42x2	37	187
25	205.5415AA	Rd 48x3	41	145
32	205.5416AA	Rd 70x3	55	200