

4/2 and 4/3 Directional Control Valve, Solenoid Operated, Wire Box

RPEW4-06

Size 06 (D03) • Q_{max} 80 l/min (21 GPM) • p_{max} 350 bar (5100 PSI)

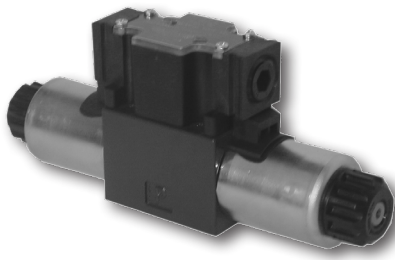

Technical Features

- › Direct acting directional control valve with subplate mounting interface acc. to ISO 4401, DIN 24340 (CETOP 03)
- › High transmitted hydraulic power up to 350 bar with optimized design to minimize pressure drop
- › Five chamber housing design with reduced hydraulic power dependence on fluid viscosity
- › Wire box for solenoid electrical connection with cable gland [1/2" NPT]
- › Optional 3-pin or 5-pin connector acc. to ANSI/B93.55M
- › Type for AC power supply with a rectifier bridge built in the wire box
- › Wide range of interchangeable spools and manual overrides available
- › CSA Certificate upon request
- › Soft-shift spool speed control option
- › Optional shift position indicators (raised arrows) installed on the terminal plate
- › In the standard version, the valve housing is phosphated and steel parts zinc-coated for 240 h salt spray protection acc. to ISO 9227

ISO 4401-03-02-0-05

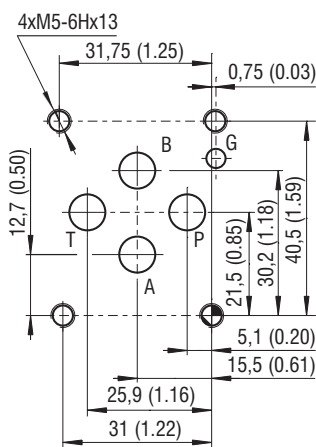

Ports P, A, B, T - max $\varnothing 7.5$ mm (0.29 in)

Technical Data

Valve size	06 (D03)		
Max. flow	l/min (GPM)	80 (21.1)	
Max. operating pressure at ports P, A, B	bar (PSI)	350 (5080) 320 (4640) for CSA	
Max. operating pressure at port T	bar (PSI)	210 (3050)	
Fluid temperature range (NBR)	°C (°F)	-30 ... +80 (-22 ... +176)	
Fluid temperature range (FPM)	°C (°F)	-20 ... +80 (-4 ... +176)	
Ambient temperature range	°C (°F)	-30 ... +50 (-22 ... +122)	
Supply voltage tolerance	%	AC: ± 10	DC: ± 10
Max. switching frequency	1/h	15 000	
Enclosure type acc. to EN 60529	IP 65		
Switching time at $v=32$ mm ² /s (156 SUS)	ON	ms	AC: 30 ... 40 DC: 30 ... 50
	OFF	ms	AC: 30 ... 70 DC: 10 ... 50
Mass	- valve with 1 solenoid	kg (lbs)	1.3 (2.8)
	- valve with 2 solenoids		1.9 (4.2)
	Datasheet	Type	
General information	GI_0060	Products and operating conditions	
Coil types	C_8007	C22B*	
Mounting interface	SMT_0019	Size 06	
Spare parts	SP_8010		

Characteristics measured at $v = 32$ mm²/s (156 SUS)

Operating limits

Operating limits for maximum hydraulic power at rated temperature and supply voltage equal to 90% nominal.

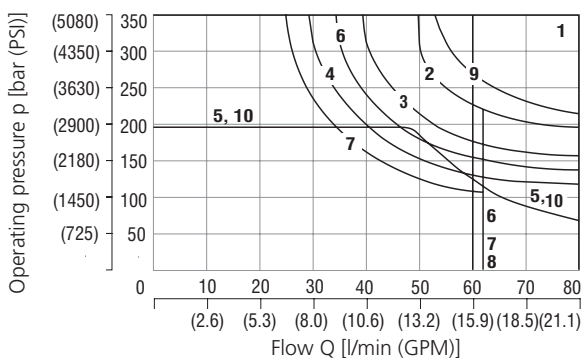

1	Z11	1	Z21	6	C51
6	C11	9	J75	1	Z51
3	H11	5	F11	7	H51
1	P11	3	R11	7	F51
2	Y11	4	R21	3	X11
5	L21	5	A51	7	N11
8	B11	1	P51	10	X25
1	J15	2	Y51		

Pressure drop related to flow rate

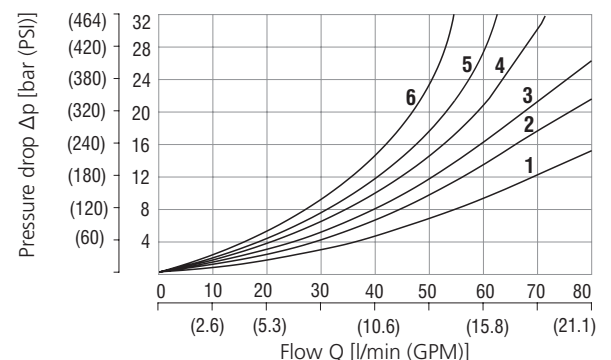

	P-A	P-B	A-T	B-T	P-T		P-A	P-B	A-T	B-T	P-T
Z11,L21,B11,R11 R21,X11,N11,J15	2	2	3	3		P51	1	3			
C11	5	5	5	6	3	Y51	2	2			
H11	2	2	2	3	3	C51	2			3	4
P11	1	1	3	3		C51	2			3	4
A51,J75	2	2				F11	1	2		3	3
Z21,Z51,H51,F51	2	3				Y11	2	2	2	2	

For operating limits under conditions and flow directions other than shown contact our technical support. Admissible operating limits may be considerably lower with only one direction of flow (A or B plugged, or without flow.)

Ordering Code

RPEW4 - 06 / -

4/2 and 4/3 directional control valve, solenoid operated, wire box

Valve size

Number of valve positions

two positions **2**
three positions **3**

Spool symbols

see the table "Spool symbols"

Rated supply voltage of solenoid

(at the wire box terminal)

12 V DC / 2.72 A

01200

24 V DC / 1.29 A

02400

120 V AC / 0.26 A, 60 Hz*

12060

*DC coils with rectifier in wire box

Connector for wire box and wire box power

DC solenoid for DC power supply

EW1K

DC solenoid for AC power supply (rectifier in wirebox)

EW1R

DC solenoid with quenching diode for DC power supply

EW2K

Wire box version, supply connector

without connector, 1/2 NPT thread at both ends (either side can be used for wiring, remove cover-plug accordingly) **50**

50 with LED (B side plugged, A side with feed-through plug) **51**

No designation **U** CSA Certified standard CSA marking

No designation Surface treatment standard

No designation **V** Seals NBR FPM (Viton)

No designation **T1** Soft-shift spool speed control without soft-shift control orifice \varnothing 0.7 mm (0.03 inch) in solenoid

No designation **N2** Manual override standard rubber boot protected

- For directional valves with two solenoids, one solenoid must be de-energized before the other solenoid can be charged.
- The orifice to the P port can be ordered separately, see data sheet SP_8010.
- Mounting bolts M5 x 45 DIN 912-10.9 or studs must be ordered separately. Tightening torque is 8.9 Nm (6.56 lbf.ft).
- Besides the commonly used valve versions shown other special models are available. Contact our technical support for their identification, feasibility and operating limits.

Spool Symbols

Type	Symbol	Interposition	Type	Symbol	Interposition	Type	Symbol	Interposition
Z11			R11			Z11		
C11			R21			X11		
H11			A51			C11		
P11			P51			H11		
Y11			X25			N11		
L21			Y51			F11		
B11			C51			J15		
Z21			Z51			J75		
F11			H51					
			F51					

Solenoid Coil for Wire Box in millimeters (inches)

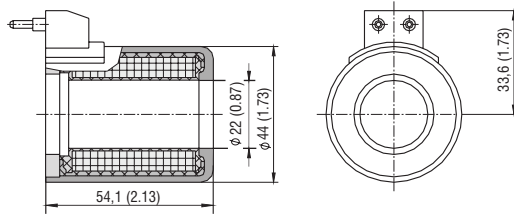

Manual Override in millimeters (inches)

No designation
- standard

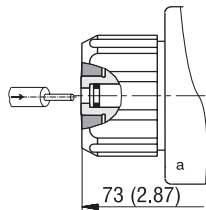

Designation N2
- rubber boot protected

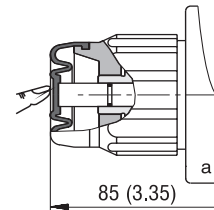

In case of solenoid malfunction or power failure, the spool of the valve can be shifted by manual override as long as the pressure in port T does not exceed 25 bar (363 PSI). For alternative manual overrides contact our technical support.

Spool Speed Control Orifice in millimeters (inches)

Designation T1

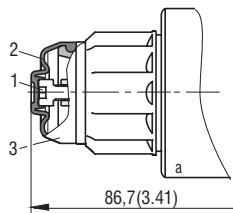

Important:

This directional valve provides the means to control spool soft shifting by an orifice situated in the solenoid armature. To ensure the proper function of the valve, unobstructed venting of the solenoid is required through the bleeding plug (1). The plugs are accessible after removing the rubber boot (2) from the solenoid cap nut (3).

Switching time ON and OFF

300 ... 800 ms

The switching times shown are valid for viscosity $\nu = 32 \text{ mm}^2/\text{s}$ (156 SUS) and nominal voltage. They depend on working pressure and flow rate of the directional control valve.

Example - connecting of connectors ANSI / B93.55M

Pinout - 3-pin connector

- 1 - green
- 2 - black
- 3 - white

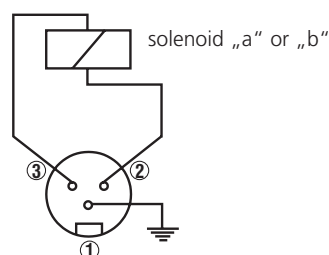
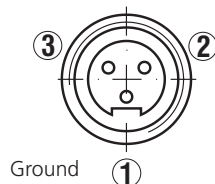

Pinout - 5-pin connector

- 1 - white
- 2 - red
- 3 - green
- 4 - orange
- 5 - black

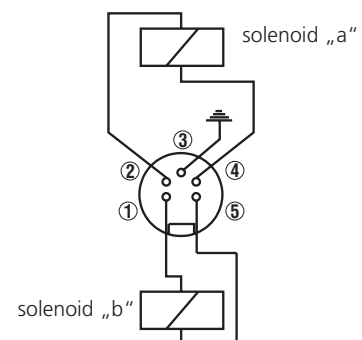
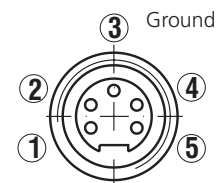

Dimensions in millimeters (inches)

Valve with two solenoids

RPEW4-063*/*EW*

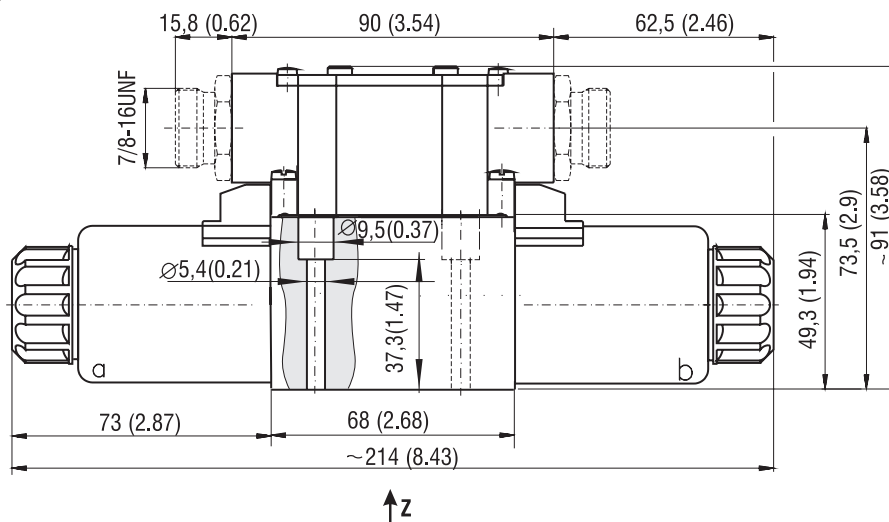

Valve with one solenoid „a”

RPEW4-062*/*EW*

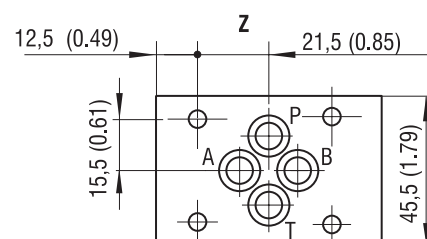
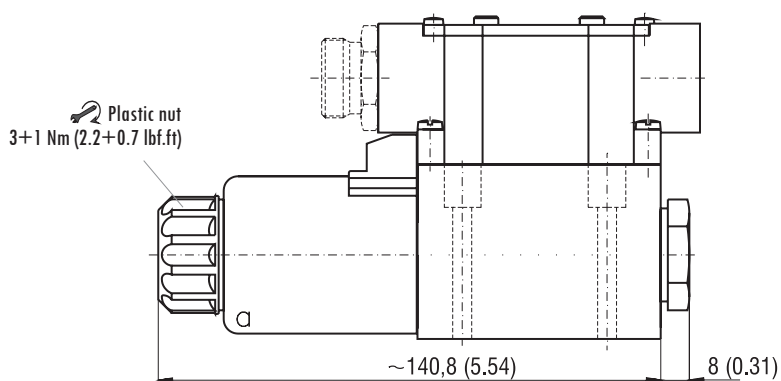

Valve with one solenoid „b”

Spool symbols X11, Z11, C11, H11, N11, F11

RPEW4-062*/*EW*

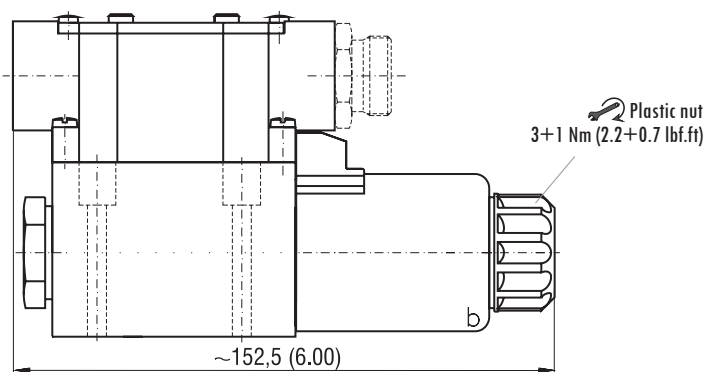

Mounting screws 8.9 Nm (7 lbf.ft)
M5 x 45 DIN 912-10.9