

Proportional Directional Control Valve, Pilot Operated

PRM8-06

Size 06 (D03) • Q_{max} 140 l/min (37 GPM) • p_{max} 350 bar (5100 PSI)

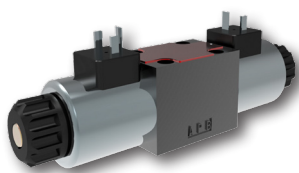

Technical Features

- › Pilot operated proportional control valve with exceptional hydraulic power limits
- › Subplate mounting surface acc. to ISO 4401, DIN 24340 (CETOP 03) standards
- › The valve opening and resulting flow rate can be modulated continuously in proportion to the reference signal
- › The valve can be controlled directly by a current control supply unit or by an electronic control unit to exploit the valve performance to the fullest
- › Analog converter card EL3E allows fine position control of the valve spool, reducing hysteresis and response time and optimizing the performance of the valve
- › Five chamber housing design with reduced hydraulic power dependence on fluid viscosity
- › Wide range of electrical terminal versions for the solenoids available
- › Wide range of interchangeable spools and manual overrides available
- › The coil is fastened to the core tube with a retaining nut and can be rotated by 360° to suit the available space
- › In the standard version, the valve housing is phosphated and steel parts zinc-coated for 240 h salt spray protection acc. to ISO 9227
- › Enhanced surface protection for mobile sector available (ISO 9227, 520 h salt spray)

Functional Description

The pilot operated main spool valve follows the control spool position, which is given by the control current to the solenoid. The solenoids are supplied from an external source, which should be provided with a current feedback. In order to achieve optimum operating parameters the external electronics should be able to generate a dither signal. The proportional valve can be used within the whole range of input pressure where the required continuity of the flow rate characteristics and minimum hysteresis is achieved.

The selected concept increases the achieved output parameters of the proportional valve in comparison to direct controlled proportional valve. The valve can be controlled directly by a current control supply unit or by means of the external electronic card directly mounted to the electrical terminal (see Catalogue of EL3E card 9145 and EL6 card 9150). This control card, depending on the number of the controlled solenoids, can be mounted onto either solenoid.

ISO 4401-03-02-0-05

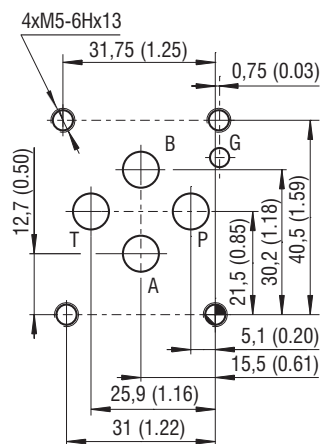

Ports P, A, B, T - max. \varnothing 7.5 mm (0.29 in)

Technical Data

Valve size		06 (D03)	
Max. operating pressure at ports P, A, B	bar (PSI)	350 (5080)	
Maximal flow at pressure 320 bar (4640 PSI)	l/min (GPM)	140 (37)	
Maximum operating pressure at port T	bar (PSI)	210 (3050)	
Fluid temperature range (NBR / (FPM))	°C (°F)	-30 .. +80 (-22 ... +176) / -20 .. +80 (-4 .. +176)	
Ambient temperature max.	°C (°F)	-30 ... +50 (-22 ... +122)	
Nominal flow rate Q_n at $\Delta p=10$ bar (145 PSI)	l/min (GPM)	25 (6.6)	
Hysteresis	%	< 6	
Mass	kg (lbs)	2.4 (5.3)	
Technical data of the proportional solenoid			
Nominal supply voltage	V	12 DC	24 DC
Limit current	A	2.5	1.0
Mean resistance value at 20 °C (68 °F)	Ω	2.3	13.4
	Data Sheet	Type	
General information	GI_0060	Products and operating conditions	
Coil types / Connectors	C_8007	C22B* / K*	
Mounting interface	SMT_0019	Size 06	
Spare parts	SP_8010		

Characteristics measured at $v = 32$ mm²/s (156 SUS)

Operating limits:

Flow direction P → A / B → T or P → B / A → T

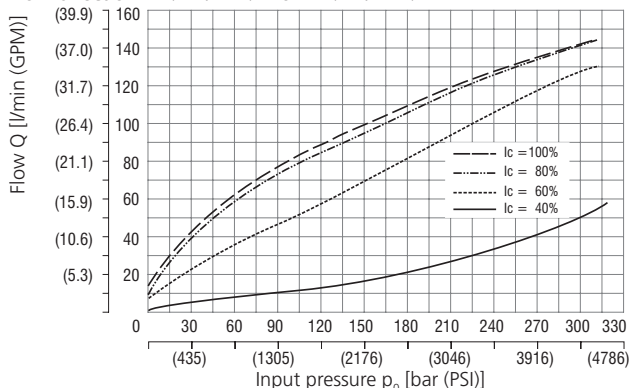

The coil current initializing the flow through the proportional directional valve can differ due to the production tolerances in a range of $\pm 6\%$ of the limit current.

Regulated flow related to control signal

$\Delta p=10$ bar (145 PSI)

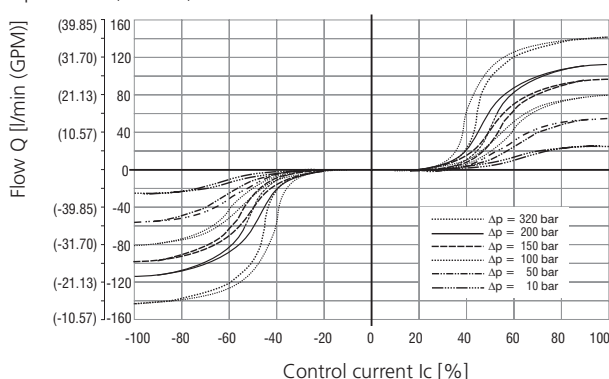

Ordering Code

PRM8-06 [] / [] - [] [] [] [] [] -1 []		No designation	Surface treatment standard
Proportional directional control valve		A	zinc-coated (ZnCr-3), ISO 9227 (240 h)
Valve size		B	zinc-coated (ZnNi), ISO 9227 (520 h)
Spool symbols	3Z11 3Y11 2Z11	Clamping lenght for mounting screw 22mm (0.86 in)	
		No designation	Seals NBR FPM (Viton)
Nominal flow rate at Δp = 10 bar (145 PSI) 25 l/min (6.6 GPM)	25	No designation N1 N2	Manual override standard protected with retaining nut protected with rubber boot
Rated supply voltage of solenoids (at the coil terminal)		E1 E2 E3A E4A E8 E9 E12A E13A	Connector EN 175301-803-A E1 with quenching diode AMP Junior Timer - axial direction (2 pins; male) E3A with quenching diode Loose conductors (two insulated wires) E8 with quenching diode Deutsch DT04-2P - axial direction (2 pins; male) E12A with quenching diode
12 V DC	12		
24 V DC	24		

- For proportional valves with two solenoids, one solenoid must be de-energized before the other solenoid can be charged.
- The solenoid operated valves are delivered without connectors. For available connectors see data sheet K_8008.
- Electronics for controlling proportional valves can be ordered separately, see catalog HA 9150.
- Mounting bolts M5 x 30 ISO 4762 or studs must be ordered separately. Tightening torque is 8.9 Nm (6.56 lbf.ft)
- Besides the shown widely used valve versions other special models are available. Contact our technical support for their identification, feasibility and operating limits.

Solenoid Coil in millimeters (inches)

E1, E2 Protection degree IP65	E3A, E4A Protection degree IP67	E8, E9 Protection degree IP65	E12A, E13A Protection degree IP67 / 69K	
				The indicated IP protection level is only achieved if the connector is properly mounted.
Dimensions: 52 (2.05) x 45 (1.77) x 32.5 (1.27)	Dimensions: 41.1 (1.62)	Dimensions: 32.5 (1.28), A	Dimensions: 46.3 (1.82)	

Manual Override in millimeters (inches)

No Designation - Standard	Designation N1 - Cap Nut Covered	Designation N2 - Rubber Boot Protected	
			In case of solenoid malfunction or power failure, the spool of valve can be shifted with a manual override under condition that the P channel is pressurized. The main spool is operated hydraulically after shifting the control spool with the manual override. The pressure in T port does not exceed 25 bar (363 PSI). For alternative manual overrides contact our technical support.
Dimensions: 73 (2.87)	Dimensions: 79.5 (3.13)	Dimensions: 89 (3.51)	

Dimensions in millimeters (inches)

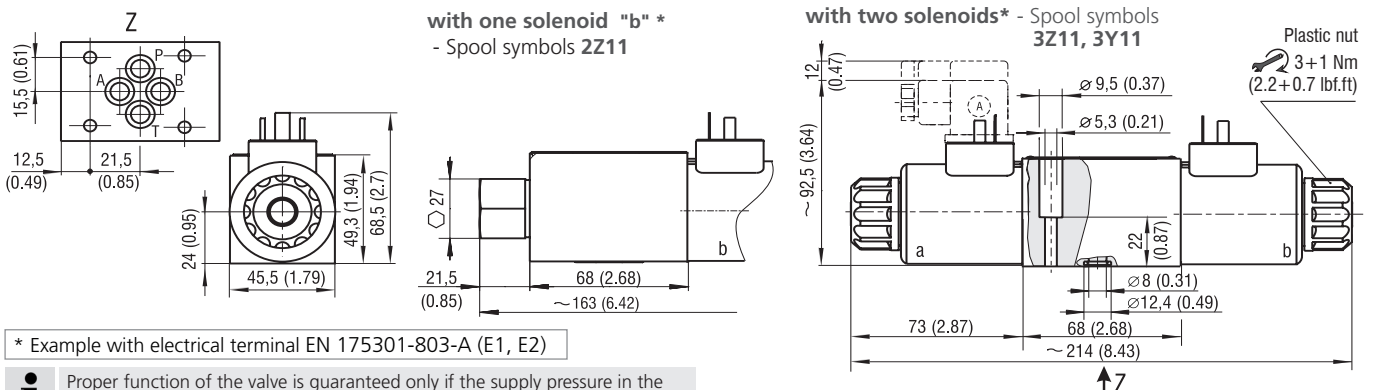

Proper function of the valve is guaranteed only if the supply pressure in the "P" channel is present and exceeds always the pressure in the "T" channel.