



CODICE ORDINAZIONE
ORDERING CODE

01	02	03
DCF		

01	VALVOLE ANTIURTO DOPPIE INCROCIATE (DOUBLE CROSS LINE DIRECT ACTING RELIEF VALVES)	DCF
02	DIMENSIONE (SIZE)	BSP 1/2 120
03	MOLLA (SPRING) 10/40 bar (145/580 PSI) max	1
	MOLLA (SPRING) 20/210 bar (290/3045 PSI) max	2
	MOLLA (SPRING) 70/350 bar (1015/5075 PSI) max	3

SCHEMA IDRAULICO / HYDRAULIC CIRCUIT

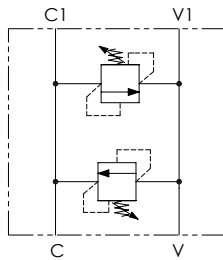

DATI TECNICI / TECHNICAL DATA

Olio idraulico - Mineral oil	ISO 6743/4 (DIN 51524)
Viscosità olio - Oil viscosity	15-250 mm²/s (15 to 250 cSt)
Classe di contaminazione max con filtro Max contamination index with filter	ISO 4406:1999 Classe 19/17/14
Temperatura dell'olio - Oil temperature	-20°C +80°C -4°F +176°F
Temperatura ambiente - Environment temperature	-20°C +50°C -4°F +122°F
È indispensabile l'utilizzo di un filtro per proteggere la valvola (filtrazione consigliata 15 µm) It is necessary a filter use to protect the valve (advised filtration 15 µm)	

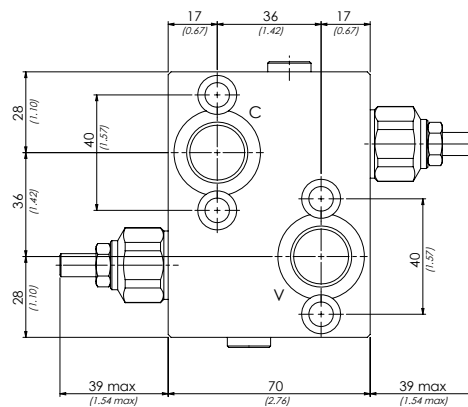
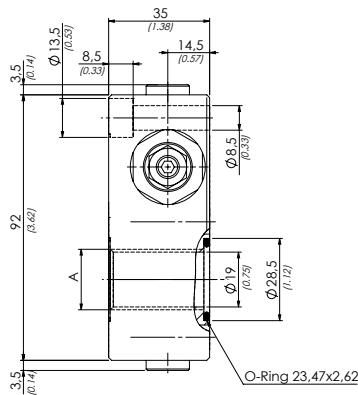

mm
Inches

CARATTERISTICHE TECNICHE / TECHNICAL CHARACTERISTICS

TIPO TYPE	A	PORTATA MAX MAX FLOW l/min-USgpm	PRESSIONE MAX MAX PRESSURE bar-PSI	PESO APPROX APPROX WEIGHT kg-lbt	VALVOLA TIPO TYPE OF VALVE
DCF120	BSP 1/2	40 (10.6)	350 (5075)	1,5 (3.3)	VMD40S

PERFORMANCES

